

# JOBBER LENGTH D20 DRILLS

For general purpose drilling applications

## 2 Helical Flutes

For use in abrasive and easily machined materials

## D20

Solid carbide





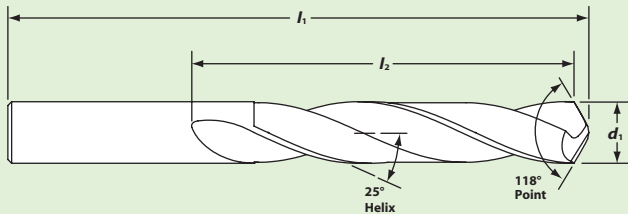

Precision ground jobber length twist drills are designed for high feed rates with good chip disposal. Solid carbide construction allows extra rigidity and is especially useful under high drilling temperatures and where greater torsional stresses are encountered.



in  $d_1 +0.0/-0.0005$

mm  $d_1 h_7$

- For most general purpose drilling applications
- Excellent in highly abrasive materials
- HARDLUBE coating (page 162) available upon request

	Carbon & tool steels $\leq 48$ HRC	✓
	Stainless steels	✓
	Cast irons	✓
	Aluminum and non-ferrous	✓✓

✓ Good ✓✓ Very Good

Inch • Metric

	$d_1$ Cutter Dia Inch    Metric	Dec Equiv	$l_2$ Flute Length	$l_1$ Overall Length	EDP Number	List Price
	1	.0394	19	38	40433	12.71
#60		.0400	3/4	1-1/2	40364	10.61
#59		.0410	3/4	1-1/2	40361	10.61
	1,05	.0413	19	38	40427	15.54
#58		.0420	3/4	1-1/2	40358	10.61
#57		.0430	3/4	1-1/2	40355	10.61
	1,1	.0433	19	38	40428	15.65
	1,15	.0453	19	38	40429	15.75
#56		.0465	3/4	1-1/2	40352	10.61
<b>3/64</b>		.0469	3/4	1-1/2	40016	10.61
	1,2	.0472	19	38	40430	15.80
	1,25	.0492	19	38	40432	16.01
	1,3	.0512	19	38	40435	16.12
#55		.0520	3/4	1-1/2	40349	10.61
	1,35	.0531	19	38	40436	16.17
#54		.0550	3/4	1-1/2	40346	10.61
	1,4	.0551	19	38	40437	16.38
	1,45	.0571	19	38	40438	15.44
	1,5	.0591	19	38	40442	12.65
#53		.0595	3/4	1-1/2	40343	10.61
	1,55	.0610	19	38	40439	15.65
<b>1/16</b>		.0625	3/4	1-1/2	40019	10.03
	1,6	.0630	19	38	40440	15.75
#52		.0635	3/4	1-1/2	40340	10.61
	1,65	.0650	19	38	40441	15.80
	1,7	.0669	19	38	40445	16.01
#51		.0670	3/4	1-1/2	40337	10.61
	1,75	.0689	19	38	40446	16.12
#50		.0700	7/8	1-3/4	40334	10.87
	1,8	.0709	22	44	40447	16.17
	1,85	.0728	22	44	40448	16.28
#49		.0730	7/8	1-3/4	40331	11.18
	1,9	.0748	22	44	40449	16.38
#48		.0760	7/8	1-3/4	40328	11.34
	1,95	.0768	22	44	40450	16.49
<b>5/64</b>		.0781	7/8	1-3/4	40022	11.13
#47		.0785	7/8	1-3/4	40325	11.34
	2	.0787	22	44	40451	13.44
	2,05	.0807	22	44	40455	12.08
#46		.0810	7/8	1-3/4	40322	11.34
#45		.0820	7/8	1-3/4	40319	11.50
	2,1	.0827	22	44	40456	13.23
	2,15	.0846	25	50	40457	13.23
#44		.0860	1	2	40316	11.97
	2,2	.0866	25	50	40458	13.23
	2,25	.0886	25	50	40459	13.44
#43		.0890	1	2	40313	11.97
	2,3	.0906	25	50	40462	13.44
	2,35	.0925	25	50	40463	13.55
#42		.0935	1	2	40310	12.02
<b>3/32</b>		.0938	1	2	40025	11.45
	2,4	.0945	25	50	40465	13.65
#41		.0960	1	2	40307	12.08

continued on next page

# JOBBER LENGTH D20 DRILLS

For general purpose drilling applications

Inch • Metric • Continued

	$d_1$ Cutter Dia Inch Metric	Dec Equiv	$l_2$ Flute Length	$l_1$ Overall Length	EDP Number	List Price
	2,45	.0965	25	50	40466	13.86
#40		.0980	1	2	40304	12.18
	2,5	.0984	25	50	40460	13.86
#39		.0995	1-1/4	2-1/4	40301	12.29
#38		.1015	1-1/4	2-1/4	40298	12.34
	2,6	.1024	31	57	40467	14.81
#37		.1040	1-1/4	2-1/4	40295	12.34
	2,7	.1063	31	57	40468	14.81
#36		.1065	1-1/4	2-1/4	40292	12.34
	2,75	.1083	31	57	40471	15.02
<b>7/64</b>		.1094	1-1/4	2-1/4	40028	12.55
#35		.1100	1-1/4	2-1/4	40289	12.55
	2,8	.1102	31	57	40475	15.02
#34		.1110	1-1/4	2-1/4	40286	12.92
#33		.1130	1-1/4	2-1/4	40283	12.92
	2,9	.1142	31	57	40476	15.59
#32		.1160	1-1/4	2-1/4	40280	13.23
	3	.1181	31	57	40469	15.38
#31		.1200	1-1/4	2-1/4	40277	13.39
	3,1	.1220	31	57	40477	16.01
<b>1/8</b>		.1250	1-1/4	2-1/4	40031	13.07
	3,2	.1260	31	57	40480	16.22
	3,25	.1280	31	57	40482	16.38
#30		.1285	1-1/4	2-1/4	40274	13.97
	3,3	.1299	31	57	40483	16.38
	3,4	.1339	34	63	40485	16.38
#29		.1360	1-3/8	2-1/2	40271	14.12
	3,5	.1378	34	63	40478	16.22
#28		.1405	1-3/8	2-1/2	40268	14.44
<b>9/64</b>		.1406	1-3/8	2-1/2	40034	15.49
	3,6	.1417	34	63	40486	16.75
#27		.1440	1-3/8	2-1/2	40265	15.02
	3,7	.1457	34	63	40489	17.43
#26		.1470	1-3/8	2-1/2	40262	15.33
	3,75	.1476	34	63	40490	18.22
#25		.1495	1-3/8	2-1/2	40259	15.38
	3,8	.1496	34	63	40491	18.22
#24		.1520	1-3/8	2-1/2	40256	15.86
	3,9	.1535	34	63	40492	18.95
#23		.1540	1-3/8	2-1/2	40253	16.43
<b>5/32</b>		.1562	1-3/8	2-1/2	40037	16.22
#22		.1570	1-3/8	2-1/2	40250	17.48
	4	.1575	34	63	40487	19.37

continued in next column

Inch • Metric • Continued

	$d_1$ Cutter Dia Inch Metric	Dec Equiv	$l_2$ Flute Length	$l_1$ Overall Length	EDP Number	List Price
#21		.1590	1-3/8	2-1/2	40247	17.69
#20		.1610	1-3/8	2-1/2	40244	17.85
	4,1	.1614	34	63	40493	20.00
	4,2	.1654	41	70	40494	20.53
#19		.1660	1-5/8	2-3/4	40241	18.53
	4,25	.1673	41	70	40495	20.53
	4,3	.1693	41	70	40498	20.79
#18		.1695	1-5/8	2-3/4	40238	18.69
<b>11/64</b>		.1719	1-5/8	2-3/4	40040	19.06
#17		.1730	1-5/8	2-3/4	40235	19.06
	4,4	.1732	41	70	40499	21.21
#16		.1770	1-5/8	2-3/4	40232	19.37
	4,5	.1772	41	70	40496	21.47
#15		.1800	1-5/8	2-3/4	40229	19.53
	4,6	.1811	41	70	40500	21.95
#14		.1820	1-5/8	2-3/4	40226	19.43
	4,7	.1850	41	70	40501	22.10
#13		.1850	1-5/8	2-3/4	40223	19.85
	4,75	.1870	41	70	40502	23.52
<b>3/16</b>		.1875	1-5/8	2-3/4	40043	19.11
	4,8	.1890	41	70	40503	22.84
#12		.1890	1-5/8	2-3/4	40220	20.16
#11		.1910	1-5/8	2-3/4	40217	20.53
	4,9	.1929	41	70	40504	23.52
#10		.1935	1-5/8	2-3/4	40214	20.84
#9		.1960	1-3/4	3	40211	21.32
	5	.1969	44	76	40505	23.94
#8		.1990	1-3/4	3	40208	21.84
	5,1	.2008	44	76	40507	25.31
#7		.2010	1-3/4	3	40205	22.10
<b>13/64</b>		.2031	1-3/4	3	40046	23.31
#6		.2040	1-3/4	3	40202	23.00
	5,2	.2047	44	76	40508	25.67
#5		.2055	1-3/4	3	40199	23.31
	5,25	.2067	44	76	40509	27.46
	5,3	.2087	44	76	40510	26.83
#4		.2090	1-3/4	3	40196	23.89
	5,4	.2126	44	76	40512	27.41
#3		.2130	1-3/4	3	40193	24.52
	5,5	.2165	44	76	40514	27.04
<b>7/32</b>		.2188	1-3/4	3	40049	24.10
	5,6	.2205	44	76	40513	28.67
#2		.2210	1-3/4	3	40190	25.46

continued on next page



## D20 Sets

Set Code	Set Contents	EDP Number	List Price
DS-1	13 pieces 1/16 to 1/4 by 64ths	41590	217.09
DS-2	29 pieces 1/16 to 1/2 by 64ths	41591	1183.77

# JOBBER LENGTH D20 DRILLS

For general purpose drilling applications

## D20



Inch • Metric • Continued

	$d_1$ Cutter Dia Inch    Metric	Dec Equiv	$l_2$ Flute Length	$l_1$ Overall Length	EDP Number	List Price
	5,7	.2244	44	76	40515	28.61
	5,75	.2264	44	76	40516	30.40
#1	.2280		1-3/4	3	40187	26.83
	5,8	.2283	44	76	40517	29.19
	5,9	.2323	51	82	40518	30.35
A	.2340		2	3-1/4	40109	29.72
15/64	.2344		2	3-1/4	40052	26.72
	6	.2362	51	82	40523	29.93
B	.2380		2	3-1/4	40112	30.50
	6,1	.2402	51	82	40519	32.34
C	.2420		2	3-1/4	40115	30.61
	6,2	.2441	51	82	40520	33.02
D	.2460		2	3-1/4	40118	31.45
	6,25	.2461	51	82	40522	33.02
	6,3	.2480	51	82	40525	33.76
1/4	.2500		2	3-1/4	40055	27.25
	6,4	.2520	51	82	91840	37.01
	6,5	.2559	51	82	40532	35.49
F	.2570		2	3-1/4	40124	33.39
	6,6	.2598	54	89	40526	35.60
G	.2610		2-1/8	3-1/2	40127	33.92
	6,7	.2638	54	89	40527	34.76
17/64	.2656		2-1/8	3-1/2	40058	29.82
	6,75	.2657	54	89	40528	35.86
H	.2660		2-1/8	3-1/2	40130	34.86
	6,8	.2677	54	89	40529	36.65
	6,9	.2717	54	89	40530	37.38
I	.2720		2-1/8	3-1/2	40133	35.54
	7	.2756	54	89	40541	39.74
J	.2770		2-1/8	3-1/2	40136	36.38
	7,1	.2795	54	89	40535	38.38
K	.2810		2-1/8	3-1/2	40139	36.70
9/32	.2812		2-1/8	3-1/2	40061	32.18
	7,2	.2835	54	89	40536	40.58
	7,25	.2854	54	89	40537	41.69
	7,3	.2874	54	89	40538	42.53
L	.2900		2-1/8	3-1/2	40142	38.48
	7,4	.2913	60	95	40539	43.37
M	.2950		2-3/8	3-3/4	40145	39.80
	7,5	.2953	60	95	40550	43.37
19/64	.2969		2-3/8	3-3/4	40064	36.59
	7,6	.2992	60	95	40540	44.47
N	.3020		2-3/8	3-3/4	40148	42.21
	7,7	.3031	60	95	40543	44.94
	7,75	.3051	60	95	40545	45.57
	7,8	.3071	60	95	40546	47.41
	7,9	.3110	60	95	40547	47.41
5/16	.3125		2-3/8	3-3/4	40067	38.90
	8	.3150	60	95	40559	44.10
O	.3160		2-3/8	3-3/4	40151	44.68
	8,1	.3189	60	95	40548	48.25
	8,2	.3228	60	95	40549	48.98

continued in next column

Inch • Metric • Continued

	$d_1$ Cutter Dia Inch    Metric	Dec Equiv	$l_2$ Flute Length	$l_1$ Overall Length	EDP Number	List Price
P		.3230	2-3/8	3-3/4	40154	46.15
	8,25	.3248	63	101	40555	49.82
	8,3	.3268	63	101	40556	50.72
21/64	.3281		2-1/2	4	40070	42.37
	8,4	.3307	63	101	40557	51.50
Q	.3320		2-1/2	4	40157	48.98
	8,5	.3346	63	101	40568	52.29
	8,6	.3386	63	101	40558	53.18
R	.3390		2-1/2	4	40160	50.51
	8,7	.3425	63	101	40565	53.81
11/32	.3438		2-1/2	4	40073	46.99
	8,75	.3445	63	101	40566	55.07
	8,8	.3465	63	101	40567	55.91
S	.3480		2-1/2	4	40163	55.49
	8,9	.3504	63	101	40570	57.70
	9	.3543	70	108	40577	59.54
T	.3580		2-3/4	4-1/4	40166	57.44
	9,1	.3583	70	108	40575	61.37
23/64	.3594		2-3/4	4-1/4	40076	51.24
	9,2	.3622	70	108	40576	61.37
	9,25	.3642	70	108	40579	62.53
	9,3	.3661	70	108	40580	63.63
U	.3680		2-3/4	4-1/4	40169	58.59
	9,4	.3701	70	108	40582	65.10
	9,5	.3740	70	108	40586	61.64
3/8	.3750		2-3/4	4-1/4	40079	55.60
V	.3770		2-3/4	4-1/4	40172	64.68
	9,6	.3780	70	108	40583	68.51
	9,7	.3819	70	108	40585	70.56
	9,75	.3839	70	108	40588	71.77
	9,8	.3858	70	108	40589	73.40
W	.3860		2-7/8	4-1/2	40175	68.57
	9,9	.3898	73	114	40590	75.02
25/64	.3906		2-7/8	4-1/2	40082	62.90
	10	.3937	73	114	40595	73.29
X	.3970		2-7/8	4-1/2	40178	74.18
	10,1	.3976	73	114	40591	78.28
	10,2	.4016	73	114	40592	80.01
	10,25	.4035	73	114	40593	82.79
Y	.4040		2-7/8	4-1/2	40181	73.66
	10,3	.4055	73	114	40594	83.16
13/32	.4062		2-7/8	4-1/2	40085	69.77
	10,4	.4094	73	114	40597	85.21
Z	.4130		2-7/8	4-1/2	40184	81.32
	10,5	.4134	73	114	40598	83.95
	10,6	.4173	73	114	40599	89.09
	10,7	.4213	73	114	40600	91.14
27/64	.4219		2-7/8	4-1/2	40088	76.34
	10,75	.4232	73	114	40601	92.77
	10,8	.4252	73	114	40602	94.40
	10,9	.4291	73	114	40603	95.97
	11	.4331	73	114	40604	93.61
	11,1	.4370	73	114	40606	99.12

continued on next page

# STUB LENGTH D21 DRILLS

For general purpose drilling applications

## D20



Inch • Metric • Continued

$d_1$ Cutter Dia Inch Metric	Dec Equiv	$l_2$ Flute Length	$l_1$ Overall Length	EDP Number	List Price
<b>7/16</b>	.4375	2-7/8	4-1/2	40091	82.69
	11,2 .4409	76	120	40607	100.22
	11,25 .4429	76	120	40608	101.85
	11,3 .4449	76	120	40609	103.53
	11,4 .4488	76	120	40610	105.21
	11,5 .4528	76	120	40612	102.22
<b>29/64</b>	.4531	3	4-3/4	40094	89.57
	11,6 .4567	76	120	40615	108.57
	11,7 .4606	76	120	40616	110.15
	11,75 .4626	76	120	40617	111.88
	11,8 .4646	76	120	40618	113.45
	11,9 .4685	76	120	40619	115.13
<b>15/32</b>	.4688	3	4-3/4	40097	96.44
	12 .4724	76	120	40613	108.73
	12,1 .4764	76	120	40620	116.76
	12,2 .4803	76	120	40625	117.55
	12,25 .4823	76	120	40626	118.23
	12,3 .4843	76	120	40627	119.02
<b>31/64</b>	.4844	3	4-3/4	40100	99.28
	12,4 .4882	76	120	40628	119.96
	12,5 .4921	76	120	40629	120.70
	12,6 .4961	76	120	40630	121.59
	12,7 .5000	76	120	40632	122.80
<b>1/2</b>	.5000	3	4-3/4	40103	101.80

continued in next column

Inch • Metric • Continued

$d_1$ Cutter Dia Inch Metric	Dec Equiv	$l_2$ Flute Length	$l_1$ Overall Length	EDP Number	List Price
	13 .5118	82	127	40633	143.80
<b>17/32</b>	.5312	3-1/4	5	97346	143.80
	13,5 .5315	82	127	40635	188.95
	14 .5512	82	127	40636	181.13
<b>9/16</b>	.5625	3-1/4	5	40106	187.16
	14,5 .5709	82	127	40637	233.78
	15 .5906	82	127	40638	223.70
<b>19/32</b>	.5937	3-1/4	5	97943	223.70
	15,5 .6102	82	127	40639	223.70
<b>5/8</b>	.6250	3-1/4	5	40107	226.12
	16 .6299	82	127	40640	202.44
	16,5 .6496	89	140	40642	303.56
<b>21/32</b>	.6562	3-1/2	5-1/2	40787	303.56
	17 .6693	89	140	40643	303.56
<b>11/16</b>	.6875	3-1/2	5-1/2	40645	282.29
	17,5 .6890	89	140	40646	282.29
	18 .7087	89	140	40647	351.54
<b>23/32</b>	.7187	3-1/2	5-1/2	40788	351.54
	18,5 .7283	89	140	40648	351.54
	19 .7480	95	152	40649	330.23
<b>3/4</b>	.7500	3-3/4	6	40108	274.37
	19,5 .7677	95	152	40719	437.22
<b>25/32</b>	.7812	3-3/4	6	40725	406.93
	20 .7874	95	152	40786	406.93

## 2 Helical Flutes



- For most general purpose drilling applications
- Excellent in highly abrasive materials
- Stub length for extra rigidity
- **TiN** coated

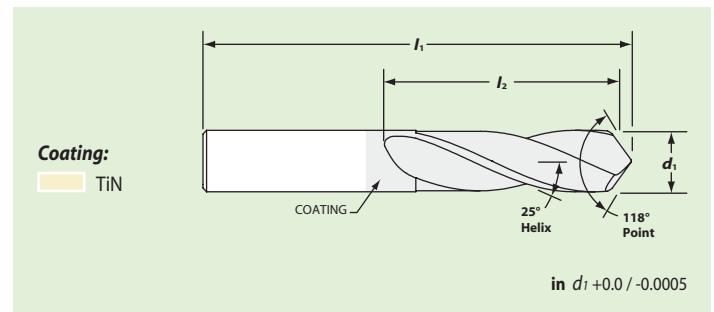

## D21

Solid carbide

	Carbon & tool steels $\leq 48$ HRC	✓
	Stainless steels	✓
	Cast irons	✓
	Aluminum and non-ferrous	✓✓

Inch

$d_1$ Cutter Dia	Dec Equiv	$l_2$ Flute Length	$l_1$ Overall Length	TiN EDP Number	List Price
1/8	.1250	5/8	2	41408	16.12
9/64	.1406	5/8	2	41409	16.59
5/32	.1562	3/4	2-1/2	41410	18.59
11/64	.1719	3/4	2-1/2	41411	21.21
3/16	.1875	3/4	2-1/2	41412	21.84
13/64	.2031	3/4	2-1/2	41413	23.99
7/32	.2188	1	2-1/2	41414	25.10
15/64	.2344	1	2-1/2	41415	27.62
1/4	.2500	1	2-1/2	41416	28.88
17/64	.2656	1	2-1/2	41417	31.08
9/32	.2812	1	2-1/2	41418	32.50
19/64	.2969	1-1/4	2-3/4	41419	35.91
5/16	.3125	1-1/4	2-3/4	41420	39.11

continued in next column

Inch • Continued

$d_1$ Cutter Dia	Dec Equiv	$l_2$ Flute Length	$l_1$ Overall Length	TiN EDP Number	List Price
21/64	.3281	1-1/4	2-3/4	41421	42.00
11/32	.3438	1-1/4	3	41422	44.78
23/64	.3594	1-1/4	3	41423	48.72
3/8	.3750	1-1/4	3	41424	49.46
25/64	.3906	1-1/4	3	41425	56.54
13/32	.4062	1-1/4	3	41426	63.89
27/64	.4219	1-1/4	3	41427	68.83
7/16	.4375	1-1/4	3	41428	72.35
29/64	.4531	1-1/4	3	41429	82.90
15/32	.4688	1-1/4	3	41430	85.37
31/64	.4844	1-1/4	3	41431	88.31
1/2	.5000	1-1/4	3	41432	90.46

✓ Good ✓✓ Very Good