

E42 END MILLS • PILOTED DIE TRIMMER

For specialty milling applications

2 Straight Flutes

For precision slotting & contouring



E42 • E42B



E42 • Square



E42B • Ball

 Carbon & tool steels ≤ 48 HRC	✓
 Carbon & tool steels > 48 HRC	✓
 Cast irons	✓

✓ Good ✓✓ Very Good ✓✓✓ Excellent

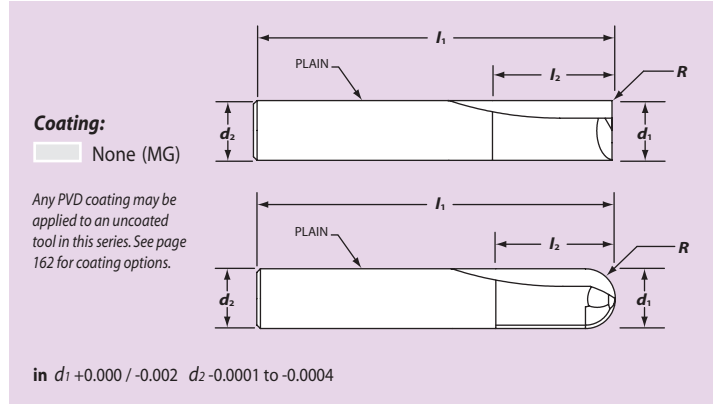

- For tight tolerance slots and keyways
- Ball end tool is excellent for contouring operations

Inch

d_1 Cutter Dia	d_2 Shank Dia	I_2 Length of Cut	I_1 Overall Length	R Corner Radius	Style Code	MG EDP Number	List Price
1/8	1/8	1/2	1-1/2	Square	RR	32207	12.64
		1/2	1-1/2	Ball	RR	32407	15.18
1/4	1/4	3/4	2-1/2	Square	RR	32215	23.16
		3/4	2-1/2	Ball	RR	32415	27.78
3/8	3/8	1	2-1/2	Square	RR	32219	33.51
		1	2-1/2	Ball	RR	32419	40.31
1/2	1/2	1	3	Square	RR	32223	57.33
		1	3	Ball	RR	32423	68.78

Style Code Reference
 RR—Regular LOC, Regular OAL

Piloted Die Trimmer

For die repair

PDT10

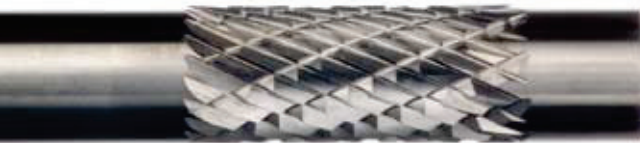

- For use in hand-held grinders
- Double cut

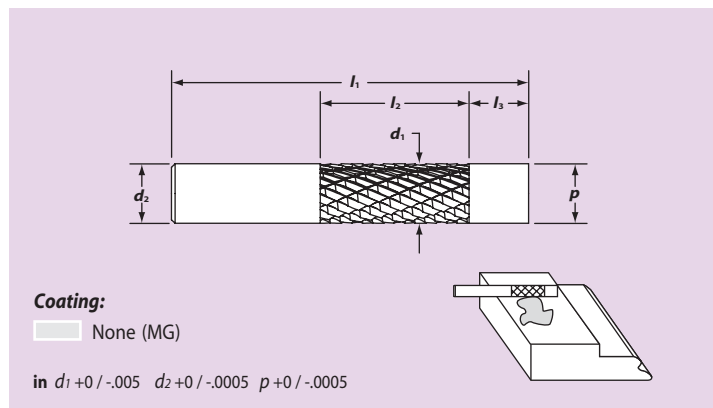

Inch

d_1 Cutter Dia	P Pilot Dia	d_2 Shank Dia.	I_2 Length of Cut	I_3 Pilot Length	I_1 Overall Length	MG EDP Number	List Price
1/8	1/8	1/8	1	1/2	2-1/2	05634	25.10
3/16	3/16	3/16	1	1/2	2-1/2	05647	26.04
1/4	1/4	1/4	1	1/2	2-1/2	05630	27.25
3/8	3/8	3/8	1	1/2	2-1/2	05643	40.69
1/2	1/2	1/2	1	1/2	2-1/2	05640	59.32